

Interactive Construction: Interactive Fabrication of Functional Mechanical Devices

Stefanie Mueller, Pedro Lopes, and Patrick Baudisch

Hasso Plattner Institute, Potsdam, Germany

{stefanie.mueller, pedro.lopes, patrick.baudisch}@hpi.uni-potsdam.de

ABSTRACT

Personal fabrication tools, such as laser cutters and 3D printers allow users to create precise objects quickly. However, working through a CAD system removes users from the workpiece. Recent interactive fabrication tools reintroduce this directness, but at the expense of precision.

In this paper, we introduce *constructable*, an interactive drafting table that produces precise physical output in every step. Users interact by drafting directly on the workpiece using a hand-held laser pointer. The system tracks the pointer, beautifies its path, and implements its effect by cutting the workpiece using a fast high-powered laser cutter.

Constructable achieves precision through tool-specific constraints, user-defined sketch lines, and by using the laser cutter itself for all visual feedback, rather than using a screen or projection. We demonstrate how *Constructable* allows creating simple but functional devices, including a simple gearbox, that cannot be created with traditional interactive fabrication tools.

Author Keywords: interactive fabrication; laser cutting; rapid prototyping; sketching; construction; mechanics.

ACM Classification Keywords: H5.2 [Information interfaces and presentation]: User Interfaces. - Graphical user interfaces.

General Terms: Design; Human Factors.

INTRODUCTION

Rapid prototyping/personal fabrication tools, such as 3D printers and computer controlled milling machines help users create one-off prototypes rapidly.

The process places CAD software at the front-end to personal fabrication tools. The use of CAD provides three main benefits over traditional woodworking tools, such as saws and wood chisels: (1) *Fast interaction*, it is generally faster to describe what to do to a software program than to operate an actual mechanical tool. (2) *Trial-and-error*: Users can *undo* mistakes and even selectively correct flaws.

Permission to make digital or hard copies of all or part of this work for personal or classroom use is granted without fee provided that copies are not made or distributed for profit or commercial advantage and that copies bear this notice and the full citation on the first page. To copy otherwise, to republish, to post on servers or to redistribute to lists, requires prior specific permission and/or a fee.

UIST'12, October 7–10, 2012, Cambridge, Massachusetts, USA
Copyright © 2012 ACM 978-1-4503-1580-7/12/10...\$15.00.

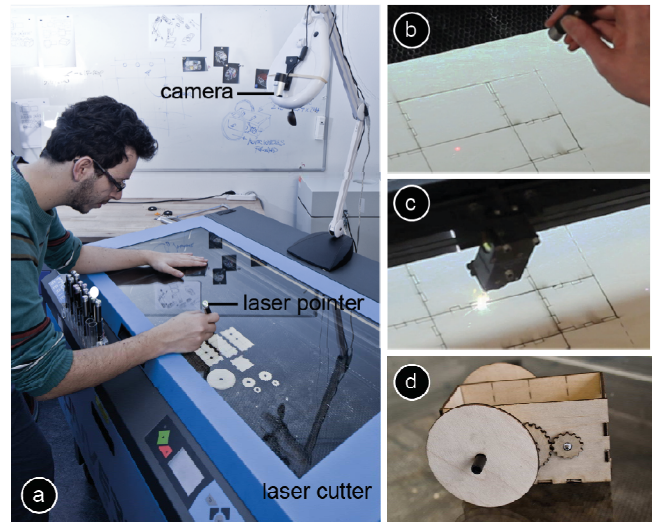

Figure 1: (a) *Constructable* users interact by drafting directly on the workpiece with hand-held lasers. (b) Here the user sketches a finger joint across two objects (c) The system responds by cutting the desired joint using the cutting laser. (d) *Constructable* allows creating precise & functional mechanical objects, such as this simple motorized vehicle.

(3) *Precision*: constructions aids, such as constraints allow users to precisely manufacture pieces that can perform mechanical functions.

On the flipside, the transition from traditional tools to personal fabrication tools means that all editing is now done on a computer screen, which removes users from the workpiece and prevents users from refining their design interactively along the way [31].

Interactive fabrication

Interactive fabrication systems address this by letting users once again work *directly* with the workpiece [31]. *CopyCAD* [8], for example, allows users to draw on the workpiece.

A key element of interactive fabrication systems is that they provide output to users not at the end of the process, but after every editing step (e.g., *Shaper* [31]). This allows users to (1) validate their designs earlier and (2) build subsequent work steps on the result of earlier steps. The related work suggests that this offers value to artists and designers [31], as their creative process is often inspired by seeing the partially completed workpiece. We argue that similar benefits can be achieved when working on technical projects.

The transition to interactive fabrication, however, comes at a cost. First, since editing is now intertwined with fabrication, editing becomes *slower*, because users have to repeatedly wait for the fabrication engine to finish. Second, as we give up on traditional tools like CAD, users lose the precision required to create functional devices.

In this paper, we attempt to put these qualities back into interactive fabrication, moving it in the direction of what we call *interactive construction*. We present *constructable*, a laser cutter-based interactive construction system that allows users to *construct* functional mechanical devices, while maintaining the immediateness of an interactive fabrication system.

CONSTRUCTABLE

Constructable is a drafting table that produces physical output in every step. As illustrated by Figure 1, all interaction in *constructable* takes place on the workpiece, mediated through low-power hand-held laser pointers, which we call *proxy lasers* or simply *tools*. In the shown example, the user uses the *finger joint* tool to add finger joints between two pieces by crossing the two involved edges.

Proxy lasers are too weak to affect the work piece. To make the interaction ‘real’, *constructable* tracks proxy laser interactions using a camera mounted above (Figure 1b), reconstructs the tool’s path, transforms it using a constraint set defined by the current tool, and implements the effect using its high-powered *cutting laser* (Figure 1c). Since all key elements were constructed in the context of constraints, we obtain fully functional mechanical devices, such as the simple motorized vehicle shown in Figure 1d.

The combination of proxy laser and cutting laser is one of the key ideas behind our system, because it allows users to work faster and more interactively than the interactive fabrication systems in the related work. The reason is that the manipulation of materials that are durable enough for making functional mechanical devices requires a *high-powered* tool. These, however, *require* safety measures, such as our glass enclosure. Opening and closing the enclosure for each interaction takes too long, but by letting users point at the workpiece *through* the safety enclosure, *constructable* allows user’s attention to remain *on the workpiece* at all times, despite the enclosure. As intended, users witness how the workpiece changes with their every interaction *first hand* and not mediated by a screen or projector.

Constructable achieves its other main design objective, i.e., *precision*, using a system of constraints implemented by the individual proxy lasers.

Proxy lasers

Figure 2 provides a closer look at the proxy lasers. Each proxy laser features three barrel buttons (Figure 2c). While held depressed, the middle button activates the beam, allowing the system and the user to see where the tool is pointed [21]. The visual feedback allows users to determine a starting point with precision before starting to cut. It thereby implements the *tracking state* of its three-state model [5].

The other two buttons trigger the tool’s two modes of operation. The *cut* button allows cutting a tool-specific shape, such as a circle for the *circle* tool. The *sketch line* button creates the same shape, but etches it as a shallow dashed line into the surface of the material. Sketch lines have no direct impact on the mechanics of the workpiece, but instead serve as alignment aids that magnetically attract subsequent cuts (*alignment lines* [3]).

All tools explain themselves exclusively through the cut or sketch line they produce and there is no further visual feedback, i.e., no screen or projector. Since all output is created using the laser cutter itself, *constructable*’s geometry output is extremely precise.

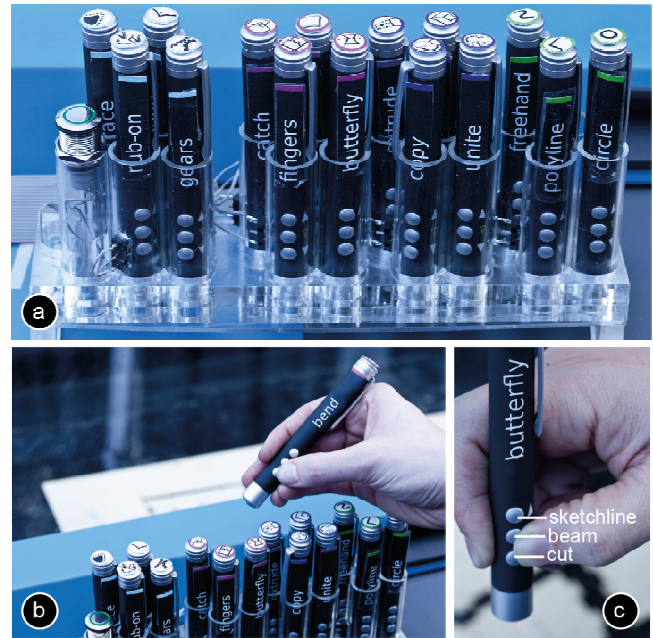

Figure 2: (a, b) *Constructable* offers 15 different proxy lasers and an undo button. (c) Each proxy-laser offers three barrel buttons.

Creating, Selecting, copying, and pasting using tools

Constructable achieves precision by means of sketch lines and by implementing constraints into every proxy laser. Constraints differ between tools.

Creating: *Polyline*, *Circle*, and *Freehand* are *constructable*’s tools for creating objects from scratch. These tools are only moderately constrained. The *circle* tool, for example, always produces a perfect circle, but diameter and location remain freehand. The *freehand* tool is not subject to any constraints.

Most of *constructable*’s tools connect to or extend an existing object and this spatial relationship adds constraints. Users establish these constraints by *selecting* one or more existing objects. The *finger joint* tool, for example, snaps to existing lines.

Selecting: As illustrated by Figure 3, users select (a) a surface by *clicking* into it, (b) an edge by *crossing* it [2], and (c) a point by drawing a *pigtail* close to it [12]. We de-

signed this selection mechanism so as to extend seamlessly to multiple objects. Users select (d) multiple surfaces by drawing a path across, (e) multiple edges by crossing multiple edges, and (f) multiple points as a sequence of multiple pigtails.

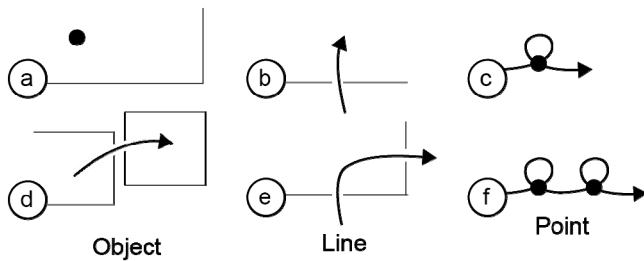

Figure 3: Constructable allows users to select (a) objects by pointing, (b) lines by crossing, and (c) points with pigtails. (d-f) To allow for fast selection, all selection gestures can be extended across multiple objects, lines, and points.

Pasting: A range of tools, such as the *copy* tool, results in the creation of new objects. The size and shape of a new object is determined implicitly, e.g., by the object being copied and does not require or allow for user input. However, to allow users to optimize material usage, we let users show constructable *where* to create it. As illustrated by Figure 4, users point constructable to available material by drawing a directional *cropmark* (see also [19]). The orientation of the cropmark specifies the orientation of the pasted object, allowing users to optimize for material use.

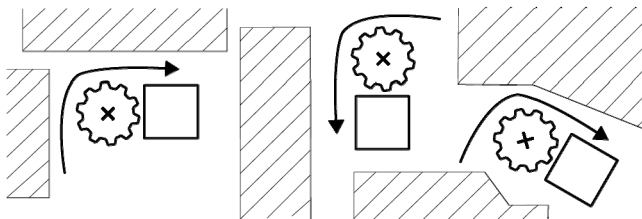

Figure 4: Users paste an object by drawing a cropmark. Constructable places the object into the “inside” of the cropmark. Cropmarks allow users to place objects carefully into available space while preventing them from cutting into adjacent contents.

WALKTHROUGH: CONSTRUCTING A DEVICE

In the following, we illustrate constructable’s tools at the example of the simple motorized vehicle that we had briefly touched upon in Figure 1. Figure 5 shows the final outcome and the pieces required to produce it.

We start by creating the housing (Figure 6). (a) We use the *polyline* tool to sketch the rectangular base. (b) Using the *sketch line* button on the *scale* tool we create a sketch line rectangle around the base—this sets the height of the walls. (c) By crossing the north edge of the base with the *Extrude* tool, we create the first wall segment. (d) For efficiency, we create the remaining three walls using a single long stroke that extrudes the base east, south, and west. There is no limit on concatenating, so we could have also extruded all

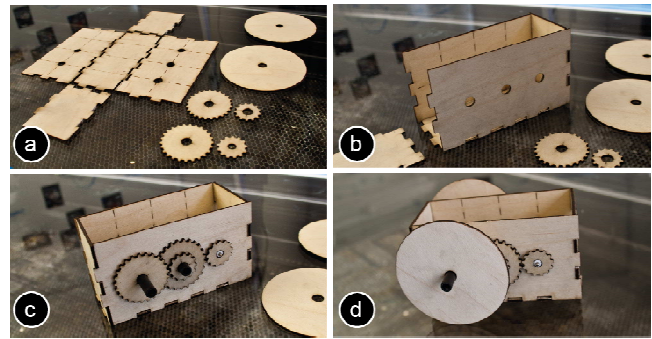

Figure 5: (a-c) The gearbox in different states of assembly, for use in (d) a simple motorized vehicle.

four walls in a single stroke. (e and f) To allow us to assemble the housing later, we add finger joints. We connect the walls by crossing pairs of respective edges using the *finger joint* tool. (g) Finally, we assemble the box by connecting the finger joints.

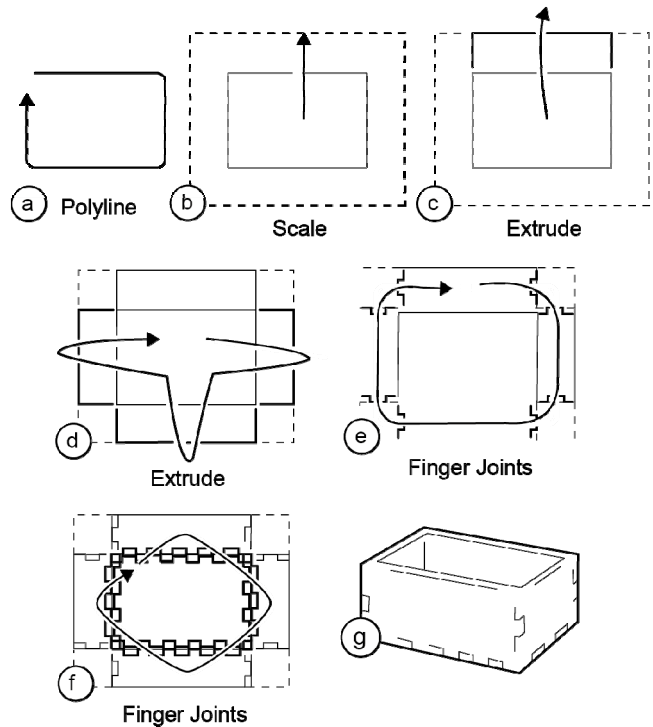

Figure 6: Interactively constructing the housing for the motorized vehicle and gearbox.

Figure 7 shows how we add gearbox and wheels. (a) To make sure that we end up with straight axles we draw three sketch lines using the *polyline* tool. (b) We create the first axle hole using the *hole* tool, the location of which snaps to the intersection of the two sketch lines located close by. (c) We draw all remaining axle holes using a single stroke concatenating multiple pigtails.

(d) We create the first pair of gears by selecting two axle holes, define the transmission ratio by marking the point where we want the two gears to meet, and show constructable where to create the gears using a cropmark. We create the second set of gears accordingly. (f) To create

a wheel, we first create an axle hole using the *hole* tool. We then create a wheel around this axle hole using the *scale* tool. (g) We create a second wheel by copying the first one using the *copy* tool.

We are now done creating our parts. We remove them from the machine and assemble them, resulting in the vehicle shown in Figure 5.

The device is mechanically functional, because every mechanical connection was created using tools that embody appropriate constraints.

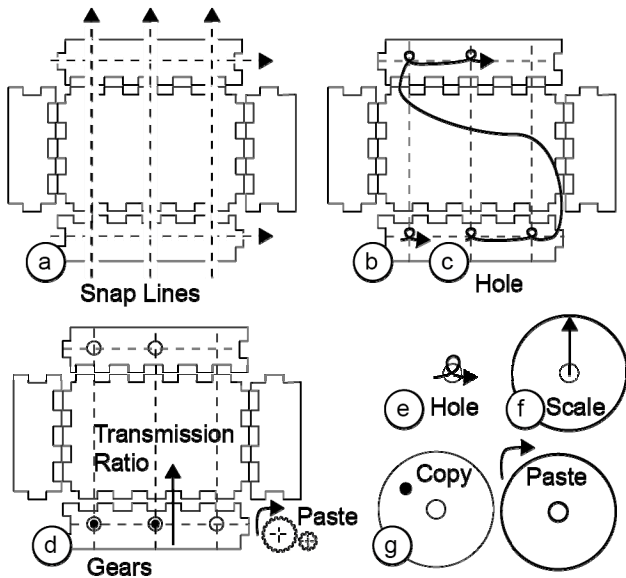

Figure 7: Continuing the previous example, we add axles, a two-stage gearbox, and wheels.

Decorative functionality

While constructable was designed with the goal of supporting interactive *construction*, its underlying concept of tools allows us to integrate form-giving (Figure 8) and decorative functionality as well (Figure 9).

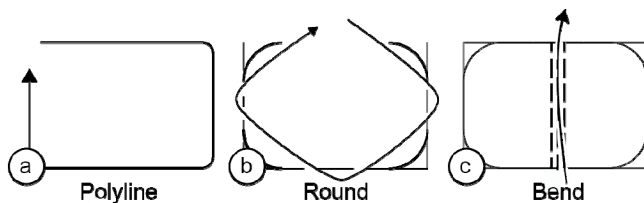

Figure 8: Creating a wooden booklet sleeve by (a) drawing the cover with the *polyline* tool, then (b) smoothing the corners with the *round* tool, and (c) making the wood flexible using the *bend* tool [1].

Figure 9 illustrates how we apply a logo to the housing of our motorized vehicle, á la *CopyCAD* [8]. (a) Continuing our earlier example, we place the housing of our motorized vehicle back into the machine, and position a photo of the desired logo on top of it. (b) We wave the *rub-on* tool across those areas of the photo that we want to transfer. (c) We take the photo back out, and as we close the lid, constructable engraves the logo into the housing.

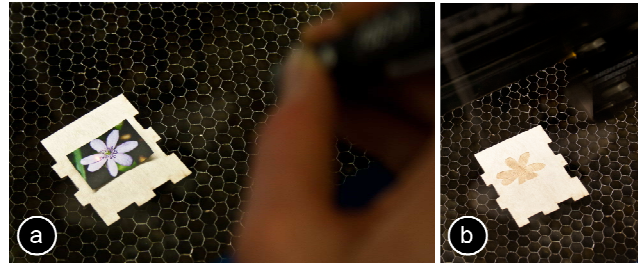

Figure 9: Adding a decorative logo onto the side of the motorized vehicle using the *rub-on* tool.

Similarly, the *trace* tool cuts the contours of a physical object into the workpiece. Figure 10 shows how to use this to create a holder for two paint jars.

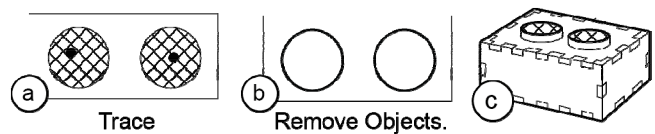

Figure 10: Creating a holder for two paint jars by (a) selecting physical objects inside the cutter using the *trace* tool, (b) After removing the physical objects constructable cuts.

Finally, we can use the *freehand* tool to create unconstrained freehand lines and cuts (Figure 11).

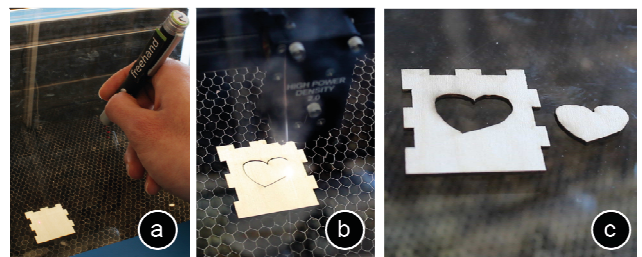

Figure 11: Sketching using the freehand tool.

Trial-and-error support using “undo” tools

Finally, constructable offers basic support for trial-and-error by providing an approximation of “undo” tools. Since physical cuts cannot be undone, constructable’s “undo” tools instead *refabricate* the object — they create a copy that does not have the cut. Users apply the tool by crossing the cuts they want removed; they then *paste* the newly restored object.

While the primary purpose of the tool is to repair and undo, the way it achieves this is by uniting two objects and copy-

ing the result. Since this functionality is useful beyond undo, we ended up giving the tool the name *union* tool.

In practice, *any* tool that unites two objects can be used as an *undo* tool. Figure 12 shows the *butterfly joint* tool, which connects two objects using a butterfly connector. This tool produces a butterfly-shaped hole across the cut and lets users paste a matching butterfly-shaped connector. Users repair the cut on assembly by placing the connector into the hole—it sits tight enough to create a lasting connection. While the union tool obviously creates the stronger connection, a butterfly joint consumes less material.



Figure 12: Undoing a cut by re-uniting the pieces using the butterfly tool.

BENEFITS AND LIMITATIONS, SUMMARY OF DESIGN

In the above walkthrough, we demonstrated *interactive construction* using constructable. We showed how constructable allows to interactively construct a functional mechanical device by bringing some of the key qualities of CAD-based personal fabrication into interactive fabrication.

Precise input and output

Constructable achieves the precision required to make functional mechanical devices as follows:

Precise input: Even though all input to constructable is mediated through a hand-held tool, the resulting jerkiness never interfered with precision because all relevant parameters are appropriately constrained. Only parameters with no functional implications, such as the size of the base of the motorized vehicle, were defined free hand.

Constructable uses three types of constraints: (1) *Each tool* implements constraints; the *polyline* tool, for example, draws only rectilinear contents. (2) *Sketch lines* allow users to add constraints explicitly. (3) A special class of tools that create connections, such as finger joints create both halves of the connection at once. As a result, finger joints always fit perfectly even though they involve two parts. The *gear tool* is based on the same concept and one might say that it connects two axles.

Precise output: As mentioned earlier, all tools explain themselves exclusively through the cut or sketch line they produce. Since this allows all output to be created using the laser cutter itself, constructable’s geometry output is extremely precise. This offers orders of magnitude higher resolution than projection and is never subject to calibration issues.

No projection

An early version of our system did feature a projector, similar to several systems in the related work, such as *CopyCAD* [8]. Letting go of it not only increased precision, but also made sure we directed users’ attention at the

workpiece at all times, rather than at a projection collocated with the workpiece.

A side effect of not having a computer display meant that we had to eliminate all hidden state and modes, because there was no way to keep users informed about them. This led us to design the proxy laser model, in which the current set of constraints is represented solely by which physical device the user is currently holding.

As another side effect of using the cutter as the sole visual feedback device, sketch lines became permanent. While users can erase sketch lines by replicating the final object using the *unite* tool, we think that users will typically choose to leave these lines in, the same way that designers leave sketch lines in to illustrate their process or even because they are esthetically pleasing [4].

Trial-and-error using “undo” tools

We implemented trial-and-error using special “undo” functions, such as the *union* and *butterfly joint* tool that allow users to re-create the previous state of an object by re-fabricating it.

Fast interaction via the proxy laser mechanism

As mentioned earlier, constructable achieves fast interaction using the proxy laser mechanism, i.e., drawing with low-power laser tools, the effect of which is implemented by a high-power cutting laser. We found the resulting interaction to invite a powerful conceptual model, namely that the cutting laser *amplifies* the proxy laser, similar to how *power brakes* and *power steering* amplify the driver’s muscle strength. We plan to develop this notion further in future versions of constructable, with the ultimate goal of causing at least the *freehand* proxy laser to invite the interpretation that it itself is cutting.

Limitations

Like any tool, constructable is useful for some design problems and less so for others. While constructable extends the range of problems that can be tackled interactively, it is obviously not a CAD system. As with traditional woodworking tools, some types of projects can be tackled tool-in-hand, while more advanced problems require users to sit down with a piece of paper first. The same way that saw and wood chisel cannot replace a detailed design process, constructable cannot replace CAD.

Another limitation is that all construction with constructable is inherently scale 1:1 and constructable offers no way of inspecting a detail in magnification. Similar to working with traditional woodworking tools, this limits users to projects that fit a particular scale.

Finally, constructable was not designed with walk-up use in mind. While some tools, such as the *finger joint* tool have the potential to make complex construction elements accessible to inexperienced users, mechanical construction in general does require know-how. Rather than addressing first time users, we designed the majority of constructable’s tools so as to be generic in nature, to apply to each other, and thereby allow for a wide range of constructions.

ERGONOMIC: THE DRAFTING TABLE FORM FACTOR

While constructable is primarily about constructive functionality, we made some observations on ergonomics.

While we initially perceived it mostly as a design hurdle, the laser cutter's glass cover turned out to become one of the key elements creating the affordance of our system. (Figure 13a). By allowing users to rest their body weight on the glass, it allows users to get even closer to the workpiece without worrying about interfering with it. Furthermore, we found ourselves resting proxy lasers on the glass while drawing (Figure 13b), which adds substantial stability, making the interaction even more precise.

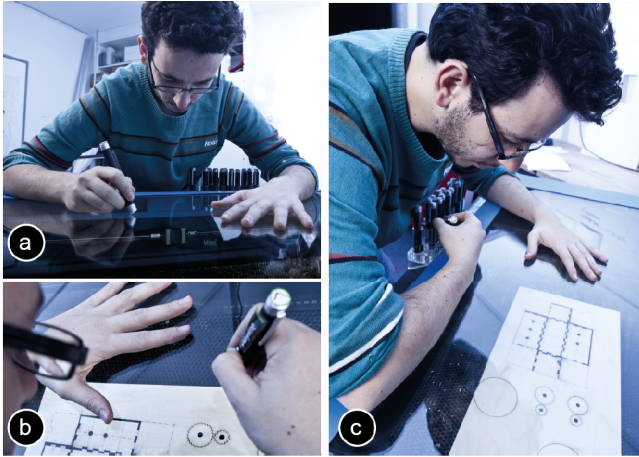

Figure 13: (a) The glass cover supports users' weight, allowing them to get close to the workpiece. (b) Resting proxy lasers onto the glass allows for precise interaction.

To invite this interpretation and posture, we positioned the proxy laser tools as shown in Figure 13c. This allows users to reach tools without lifting their arm, but instead pivoting around their elbows similar to the *Lagoon* in *Alias Sketchbook* [6].

We found all of the above to invite the interpretation of constructable as a drafting table, the “drawing” on which is the actual physical object itself. We plan on building on this interpretation in future versions by tilting the glass cover slightly towards the user (e.g., as in *ActiveDesk* [7]).

CONTRIBUTION

The main contribution of this paper is the concept of *interactive construction*, which we support with the functional system prototype constructable. Our demo scenarios illustrate how users can create functional mechanical devices, which exceeds the complexity of examples created in the interactive fabrication literature. We are thus primarily making a systems contribution.

In addition, our system contains a series of novel elements, including (a) the proxy laser mechanism, i.e., drawing with low-power laser tools, the effect of which is implemented by a high-power cutting laser, (b) the use of the laser cutter as a super high precision display, replacing projection, and

(c) the notion of undoing a physically destructive action by re-fabricating the broken piece.

RELATED WORK

The work presented in this paper builds on sketching, personal fabrication, and interactive fabrication.

Creating structured drawings from manual input

Several researchers have demonstrated how to create precise input from rough sketchy input (e.g., *ScanScribe* [28]). Many systems simplify the problem by representing additional domain knowledge [16] to resolve ambiguity [11]. Geometric constraints can bring precision for sketching tasks, (e.g., *snap dragging* [3]).

More recently, this style of constrained and precise sketch input has been synergized with interactive surfaces, such as on *Hands-On Math* [32] and *Pen+Touch* [14].

Compared to pen or touch input, lasers are a particularly imprecise input mechanism due to the unsteadiness of the hand, which causes jitter unless resting against a surface [24, 21].

Personal Fabrication

With personal fabrication tools researchers commonly refer to some superset of milling machines, laser cutters, and 3D printing machines. The main goal of personal fabrication is to allow for rapid prototyping, with the intent of reduced costs compared to actual fabrication, thereby allowing for a more iterative design process.

The concept has support not only in research, but also in the open source/DIY community, which is leading the development of more accessible machines, such as *Lasersaur* [17] and *MakerBot* and to the opening of workshops equipped with rapid-prototyping tools (denoted as *fab labs* [10]).

A range of projects aim at lowering the entry barrier to 2D and 3D modeling by restricting the space of possible objects to chairs (*SketchChair* [26]), plush animals (*Plushi* [20]), geometrical 3D shapes (*PaperFactory* [27]), 2D shapes (*Sketch it, Make it* [15]).

Finally, fabrication tools have been used as means to artistic expression, e.g., *Haptic Intelligentsia* [18] users fabricate objects around virtual models using a glue gun attached to a force-feedback haptic device.

Personal Fabrication using Laser Cutters

Laser cutters are one of the preferred personal fabrication devices, since they are powerful and fast.

SpatialSketch [30] and *FurnitureFactory* [23] allow users to sketch objects in 3D. Once the sketching is completed, the system decomposes it into a 2D model that can be batch fabricated with a laser cutter. *SpatialSketch* users draw mid-air gestures, while *FurnitureFactory* users interact via a sketch-based graphical user interface.

LaserCooking [9] uses the laser cutter as a cooking tool. It identifies specific food items by color and handles them appropriately. *MetaCookie* [22] uses a laser to engrave

augmented reality markers into cookies with augmented flavors.

Interactive Fabrication

One of the first interactive fabrication tools was *ModelCraft* [29]. It allowed users to draw onto a paper model using an Anoto digital pen, allowing the system to beautify the user’s sketches and to keep a history log for versioning and undoing.

While users of *ModelCraft* still had to manually fabricate the models by printing and folding, combining the approach with personal fabrication tools allowed closing the loop. *Interactive fabrication*, a term introduced by Willis et al. [31] replaces the batch processing common in personal fabrication with alternation between user and system control. Their tool (*Shaper* [31]) allows users to create foam sculptures via a transparent touchscreen.

CopyCAD [8] extends this concept by allowing users to include geometry from real world objects, e.g., by copying the shape of an object (*remixing*) and replicate it using a milling machine.

With *constructable*, we introduce interactive construction, extending interactive fabrication towards precision, thus allowing users to create functional mechanical devices.

IMPLEMENTATION

Figure 14 shows how *constructable* processes proxy laser input in order to generate cutting laser output.

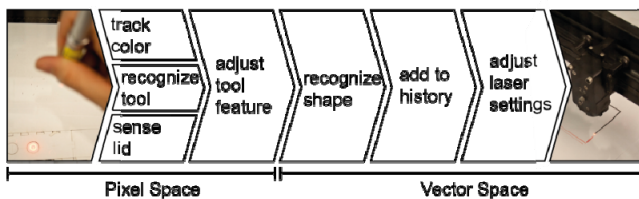

Figure 14: Data processing flow in *constructable*.

Sensing

Constructable observes the workpiece using a web cam (*MS Lifecam, 844x448px, 30 fps*) and extracts the dot produced by the proxy-lasers using color tracking. *Constructable* then smoothes tool paths using a Kalman Filter and performs shape recognition on paths using *PaleoSketch* [25] before applying the geometric operations and spatial constraints defined by the tool.

At this point, *constructable* records the interaction history, which it uses to support *undo* and selective repairs using the *union* tool.

Output to the laser cutter

Constructable now outputs the shape to the laser cutter, currently a *Universal PLS6.150D*. Using the *OpenDraw* API, *Constructable* draws the shape into an *OpenDraw* document, which it sends to the cutter using the printer interface. As required by *Universal* laser cutter systems, *constructable* encodes the necessary meta-information into the color of the respective line, i.e., cutting-depth (mm), laser power (percentage), and speed (percentage). A red Opt

line, for example, causes the laser to cut, while green is used to create a shallow, low-power *sketch line*. *Constructable* sends all communication using the *Open Sound Protocol*, which makes it easy to adapt the system to other hardware components, such as a different laser cutter model.

Remixing: using physical objects as a reference

Constructable captures physical objects using the same camera that tracks the laser dots. A bar of fluorescent light mounted inside the cutter supports this by providing homogeneous, reflection-free illumination of the workpiece. An IR rangefinder sensor informs the system when the lid is open.

Proxy lasers

In order to retrieve the constraint set represented by the current tool, *constructable* determines which tool is in use using mechanical switches, one of which is installed in each tool holder (similar to pen “recognition” in *SmartBoards*, smarttech.com). This bypass allows us to implement all proxy lasers using a single type of off-the-shelf laser pointer. The buttons on all proxy lasers trigger an IR signal, which *Constructable* monitors using an IR receiver placed next to the camera.

Similar to the *tracking* button, the *cut* and *sketch line* buttons are spring-loaded in order to eliminate mode errors [13]. Users operate them without letting go of the *tracking* button, which users perform by rocking their finger back and forth between *tracking* button and the center position of *tracking* and *cut* button. For optimized ergonomics during prolonged use [13] *constructable* offers a dual-footswitch pedal, which is fulfilling the same purpose as the *cut* and *sketch line* barrel buttons.

CONCLUSION

In this paper, we proposed *interactive construction* as a way to enable users to interactively create functional mechanical devices. Our prototype called *constructable* serves as a drafting table that produces physical output in every step. By building constraints into tools, providing sketch lines and by using the laser cutter itself for high precision output, *constructable* offers the necessary precision required to produce simple, yet functional mechanics that cannot be created with traditional interactive fabrication tools.

Equally important, *constructable* allows for fast fabrication by making a high-power cutting laser accessible to the user via safe low-power proxy lasers.

As future work, we plan to extend *constructable* to allow for collaborative use.

ACKNOWLEDGEMENT

We thank Mike Sinclair for sharing his wisdom on uncommon laser-cut joints, Ken Hinckley, Sean Gustafson, and Christian Holz for feedback.

REFERENCES

1. Booklets—it's just wood!
http://www.snijlab.nl/?page_id=358
2. Apitz, G. and Guimbretière, F. CrossY: A Crossing-Based Drawing Application. *Proc UIST'04*, 3-12.
3. Bier, E. Snap dragging. In *Proc. SIGGRAPH'86*, pp. 233-240.
4. Buxton, B. *Sketching User Experiences: Getting the Design Right and the Right Design*. Morgan Kaufman, 2007.
5. Buxton, W. A Three-State Model of Graphical Input. *Proc. INTERACT '90*, 449-456.
6. Fitzmaurice, G., Khan, A., Pieké, R., Buxton, W & Kurtenbach. G. Tracking Menus. *Proc. UIST'03*, 71-79.
7. Fitzmaurice, G.W., Ishii, H. & Buxton, W. Bricks: Laying the Foundations for Graspable User Interfaces. *Proc. CHI'95*, 442-449.
8. Follmer, S., Carr, D., Lovell, E., Hiroshi, I. CopyCAD: remixing physical objects with copy and paste from the real world. *Adjunct Proceedings UIST '10*, 381-382.
9. Fukuchi, K., Jo, K. Laser Cooking: an Automated Cooking Technique using Laser Cutter. In *TEI'11 Work-in-Progress*.
10. Gershenfeld, N. *Fab: The Coming Revolution on Your Desktop--From Personal Computers to Personal Fabrication*. Basic Books, 2007.
11. Gross, M., and Do, EYL. Ambiguous Intentions: A paper-like interface for creative design. In *Proc. UIST'96*, 183-192.
12. Hinckley, K., Baudisch, P., Ramos, G., and Guimbretiere, F. Design and Analysis of Delimiters for Selection-Action Pen Input Phrases in Scriboli. *Proc. CHI'05*, 451-460.
13. Hinckley, K., Guimbretiere, F., Baudisch, P., Sarin, R., Agrawala, M., & Cutrell, E. The Springboard: Multiple Modes in One Spring-Loaded Control. In *Proc. CHI'06*, 181-190.
14. Hinckley, K., Yatani, K., Pahud, M., Coddington, N., Rodenhouse, J., Wilson, A., Benko, H., Buxton, B. Pen + touch = new tools. *Proc. UIST'10*, 27-36.
15. Johnson, G., Do, E.Y-L. Sketch It, Make It: Sketching precise drawings for laser cutting. In *Extended Abstracts CHI '12*.
16. Landay, J. and Myers, B. Interactive Sketching for the Early Stages of User Interface Design. In *Proc. CHI '95*. 43-50.
17. Lasersaur <http://labs.nortd.com/lasersaur>
18. Lee, J.H. *Haptic Intelligentsia*. <http://studio-homunculus.com/portfolio/haptic-intelligentsia-human-prototyping-machine>.
19. Liao, C., Guimbretière, F., Hinckley, K. PapierCraft: a command system for interactive paper. *Proc. UIST'05*, 241 - 244.
20. Mori, Y., Igarashi, T. Plushie: An Interactive Design System for Plush Toys. *Proc. SIGGRAPH '07*.
21. Myers, B.A., Bhatnagar, R., Nichols, J., Peck, C.h., Kong, D., Miller, R., Long, A.C. Interacting At a Distance: Measuring the Performance of Laser Pointers and Other Devices. *Proc. CHI '02*, 33-40.
22. Narumi, T., Nishizaka, S., Kajinami, T., Tanikawa, T., Hirose, M. Augmented Reality Flavors: Gustatory Display Based on Edible Marker and Cross-Modal Interaction. *Proc. CHI '11*, 93-102.
23. Oh, Y., Johnson, G., Gross, M., Do, E.Y. The Designosaur and the Furniture Factory. *Proc. Design Computing and Cognition '06*, 123 - 140.
24. Olsen Jr, D.R. and Nielsen, T. Laser Pointer Interaction. *Proc. CHI'01*, 17-22.
25. Paulson, B. and Hammond, T. A System for Recognizing and Beautifying Low-level Sketch Shapes Using NDDE and DCR. *Adjunct Proceedings UIST'07*.
26. Saul, G., Lau, M., Mitani, J., and Igarashi, T. SketchChair: An All-in-one Chair Design System for End Users. *Proc. TEI '11*, 73-80.
27. Saul, G., Xu, C., Gross, M.D. Interactive Paper Devices: End-user Design & Fabrication. *Proc. TEI '10*, 205-212.
28. Saund, E., Fleet, D., Lerner, D., and Mahoney, J. Perceptually-Supported Image Editing of Text and Graphics, *Proc. UIST '03*, 183-192.
29. Song, H., Guimbretière, F., Hu, C., Lipson, H. ModelCraft: capturing freehand annotations and edits on physical 3D models. *Proc UIST '06*, 13-22.
30. Willis, K.D.D., Lin, J., Mitani, J., Igarashi, T. Spatial sketch: bridging between movement & fabrication. *Proc. TEI '10*, 5-12.
31. Willis, K.D.D., Xu, C., Wu, J.K., Levin, G., Gross, M.D. Interactive fabrication: new interfaces for digital fabrication. *Proc. TEI '11*, 69-72
32. Zeleznik, R., Bragdon, A., Adeputra, F., and Ko, HS. Hands-On Math: A Page-based Multi-touch and Pen Desktop for Technical Work and Problem Solving. *Proc. UIST'10*, 17-26.